

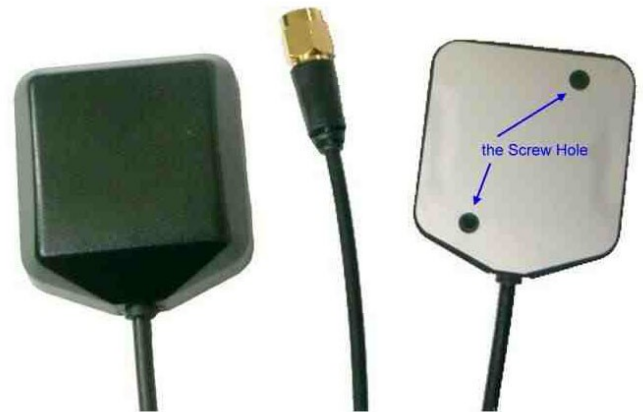

Mini GPS Antenna

Features

- Mini GPS Antenna with High Gain
- 1575.42MHz +/- 1MHz
- Active gain: +5dB
- VSWR < 1.5:1
- 5metres RG174 Cable
- SMA or MMCX Male Connector
- Dimensions 38 x 34 x 12 (Approx.)
- Mag Mount and Screw Fix



Applications

- Car GPS Systems
- Hand held GPS Systems

Description

A compact Antenna for GPS applications where high performance is required from a small size. The antenna includes a Low Noise Amplifier and incorporates both magnetic mount and screw fixings.

Ordering Information

Part Number	Description	Cable Length	Connector
ANT-GPSMG	Active GPS with cable and connector	5metres	SMA (M)
ANT-GPSMG-MMCX	Active GPS with cable and connector	5metres	MMCX (straight)

Mechanical Details

ANT-GPSMG

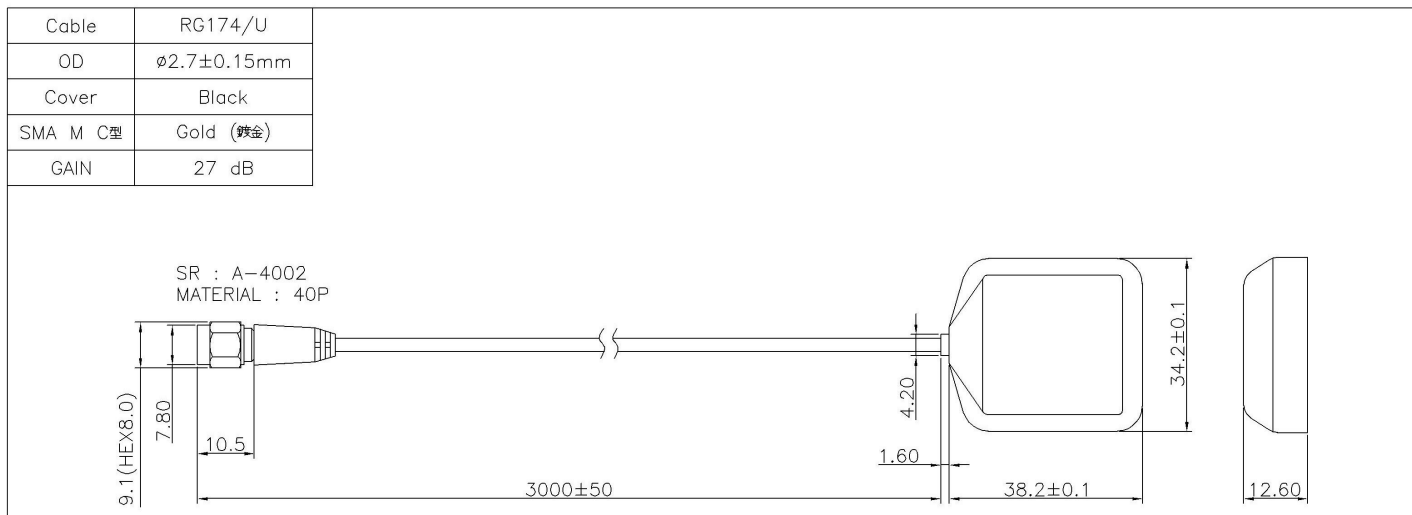

Material:		Treatment:		TEKFUN CO., LTD. 得方國際有限公司			
Drawer	Design	Aprov	Tolerance	Unit: mm		TITLE	
			X=±0.5	Ver: A	Scale 1:1	Model NO	GPS-03A
			.X=±0.2	File NO: QR0402		Drawing NO	
			.XX=±0.1				
			.XXX=±0.05				

Mounting holes

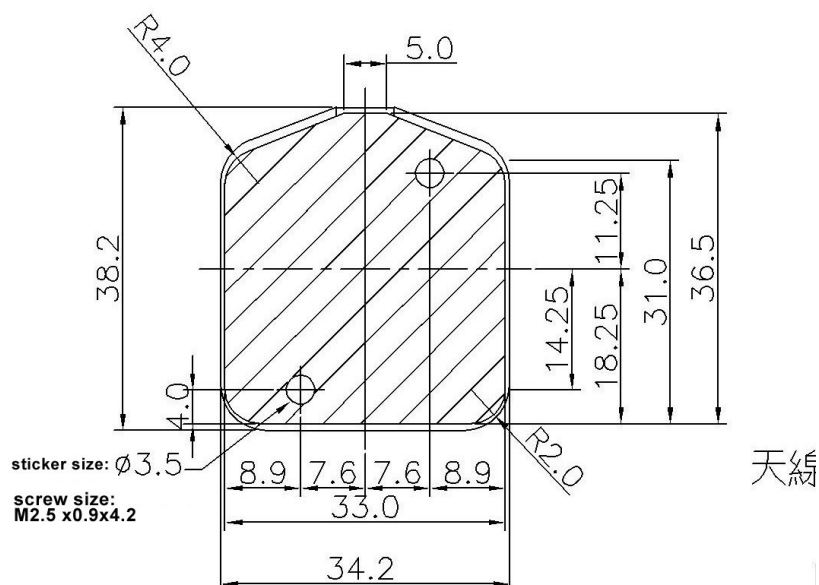

天綫

Mechanical Details

ANT-GPSMG-MMCX

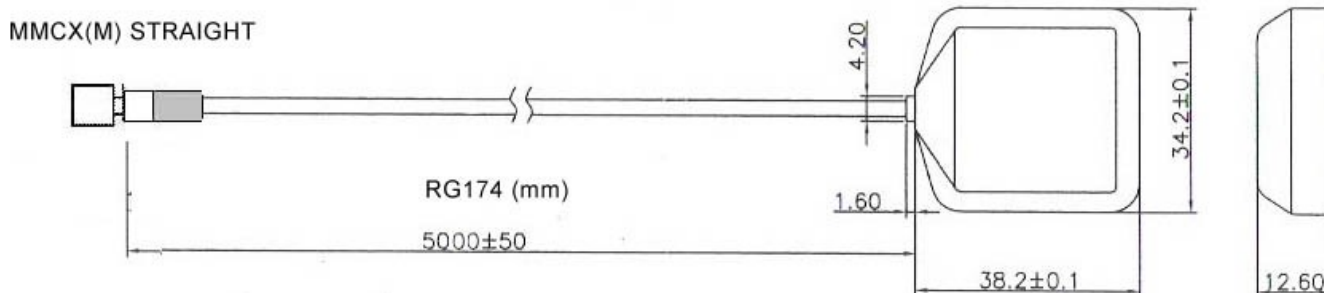

Test Data

GENERAL

3.1 ENVIRONMENTAL CONDITIONS

3.1.1 OPERATING TEMPERATURE	-40°C TO +85°C
3.1.2 STORAGE TEMPERATURE	-40°C TO +90°C (110°C MAX 1HR.)
3.1.3 RELATIVE HUMIDITY	20% TO 95%, rain

3.2 ELECTRICAL SPECIFICATIONS

3.2.1 INPUT VOLTAGE Require:	2.5 to 5.5 VDC
3.2.2 POWER CONSUMPTION	10~25 mA
3.2.3 OUTPUT CONNECTOR	SMA male
3.2.4 CABLE Shikoku Cable	RG174U Loss at 1575 MHz < 1.32 dB per meter

3.3 MECHANICAL SPECIFICATIONS

3.3.1 MOUNTING	Magnetic Mount
3.3.2 PULLING FORCE OF MAGNET	29.4N Min.
3.3.3 WATER PROOF	Waterproof (JISD0203 S2)
3.3.4 SHOCK	50G : Vertical Axis 30G : All Axis
3.3.5 VIBRATION	10 through 200Hz. Log sweep 3.0G (Sweep Time : 15 MIN.) 3 AXIS
3.3.6 MAGNET MOUNT	Withstand speed of upto 180Km/h.
3.3.7 CABLE PULLING FORCE	49N. Before Visible or electrical damage appears applying up to 49N pulling force between cable and antenna as well as between cable and connector.
3.3.8 BENDING TEST 1" radius	After bending test 90 degree right and left 1,000 cycles, no permanent damage found.
3.3.9 ANTI-COROSION	Based on JIS Z 2371, spray 5% saltwater at 35°C should not rust after 96Hrs,
3.3.10 Dimensions	See mechanical diagram.

4.0 ANTENNA

4.1 Outline Dimension	25x25x4 mm
4.2 FREQUENCY RANGE (minimum)	1,575.42 + 1.1 MHz
4.3 Frequency rejection (low side)	-10 dB or more rejection below 1500MHz
4.4 Frequency rejection (high side)	-10 dB or more rejection above 1650MHz
4.5 GAIN	1.0dBi minimum When mounted on a 25x25mm diameter metal ground plane
4.6 POLARIZATION	RHCP
4.7 AXIAL RATIO	3 dB MAX.
4.8 Bandwidth	10MHz

5.0 LNA

5.1 FREQUENCY RANGE (minimum)	1,575.42 + 1.1 MHz
5.2 GAIN	32dB +3 dB (+30°C) 32dB +4 dB (-40°C to +85°C)
5.3 NOISE FIGURE	1.8 dB MAX. (+30°C)
5.4 OUT OF BAND REJECTION	fo = 1,575.42 MHz fo + 20MHz 7dB MIN. fo + 30MHz 12dB MIN. fo + 50MHz 20dB MIN. fo + 100MHz 30dB MIN.
5.5 OUTPUT IMPEDANCE	50ohm
5.6 OUTPUT VSWR	2.0:1 MAX.

6.0 Other Specifications

6.1 ESD	ANTENNA SURFACE 15KV CONNECTOR PIN 8KV (TEST CONDITION JASOD001-94 C-3)
6.2 WEEE & Rohs compliant	Yes
7.0 MTBF	2,000 Hours
8.0 RECOMMENDED STORAGE CONDITION	-20°C~+45°C, HUMIDITY 80%MAX.
9.0 EXTERNAL APPEARANCE	NO VISIBLE STAIN OR FLAW.
10 Supplied DATA	GAIN and Current CONSUMPTION 5.0V +0.2VDC At 1575 MHz 30 degrees C.

● Experimental Results:



▲ Return Loss



▲ Test Gain Pattern Setup (Antenna with 70mm*70mm ground)

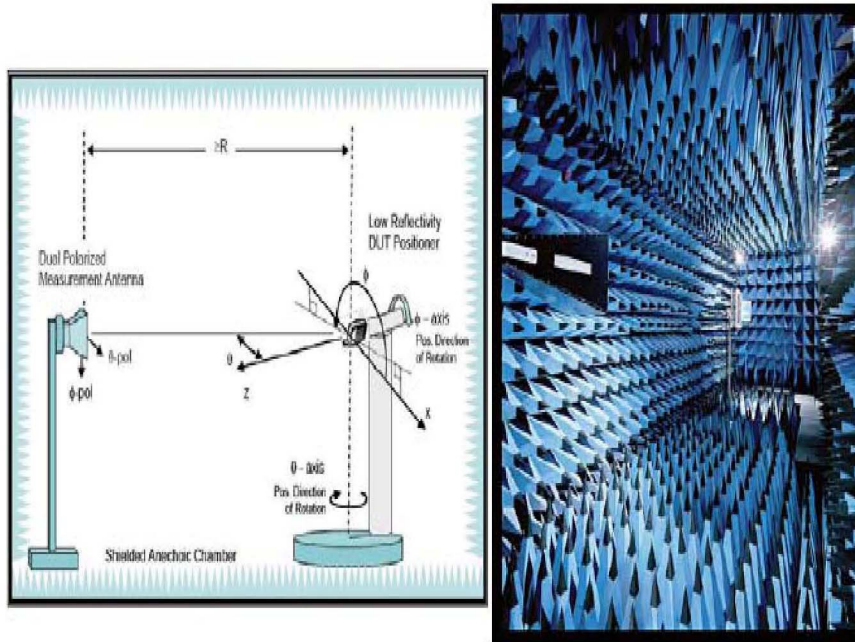

Antenna Pattern Measurement

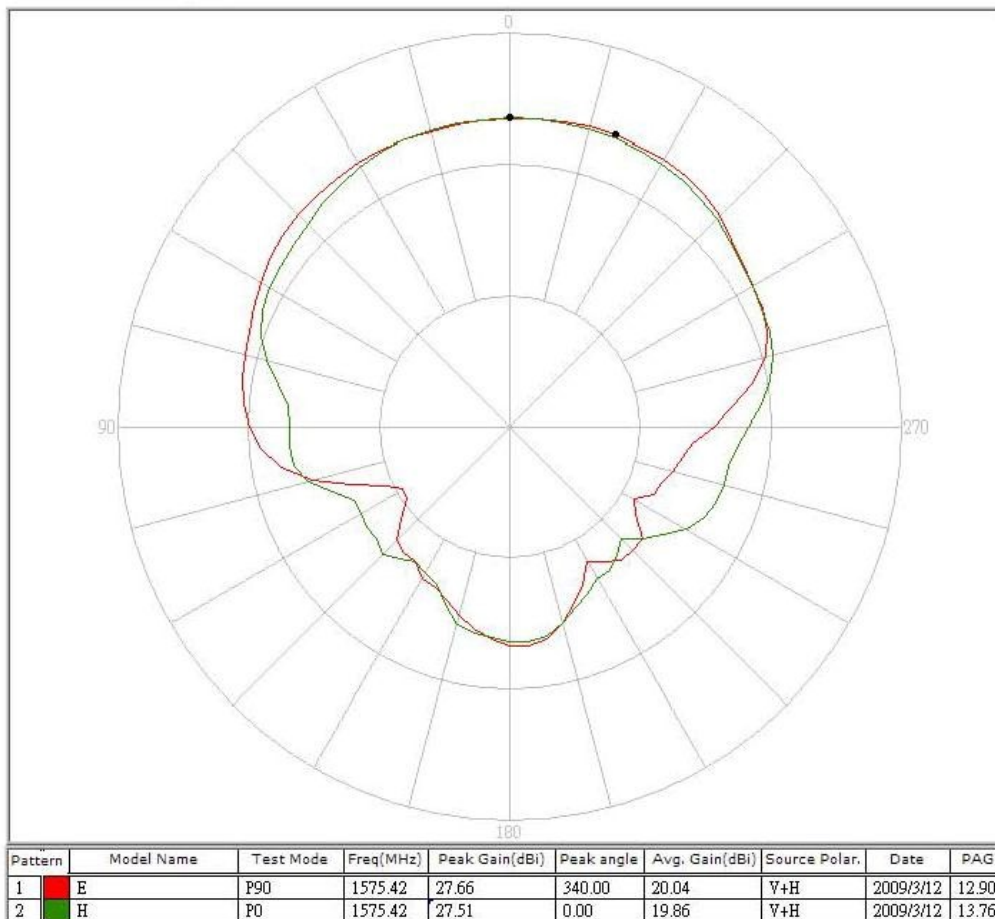

7M CABLE GPS ANTENNA 3D PATTERN(at 3.0V)

XY

Model name

GPS ANTENNA

Test frequency / Polarization

1575.42 MHz / Vector XY

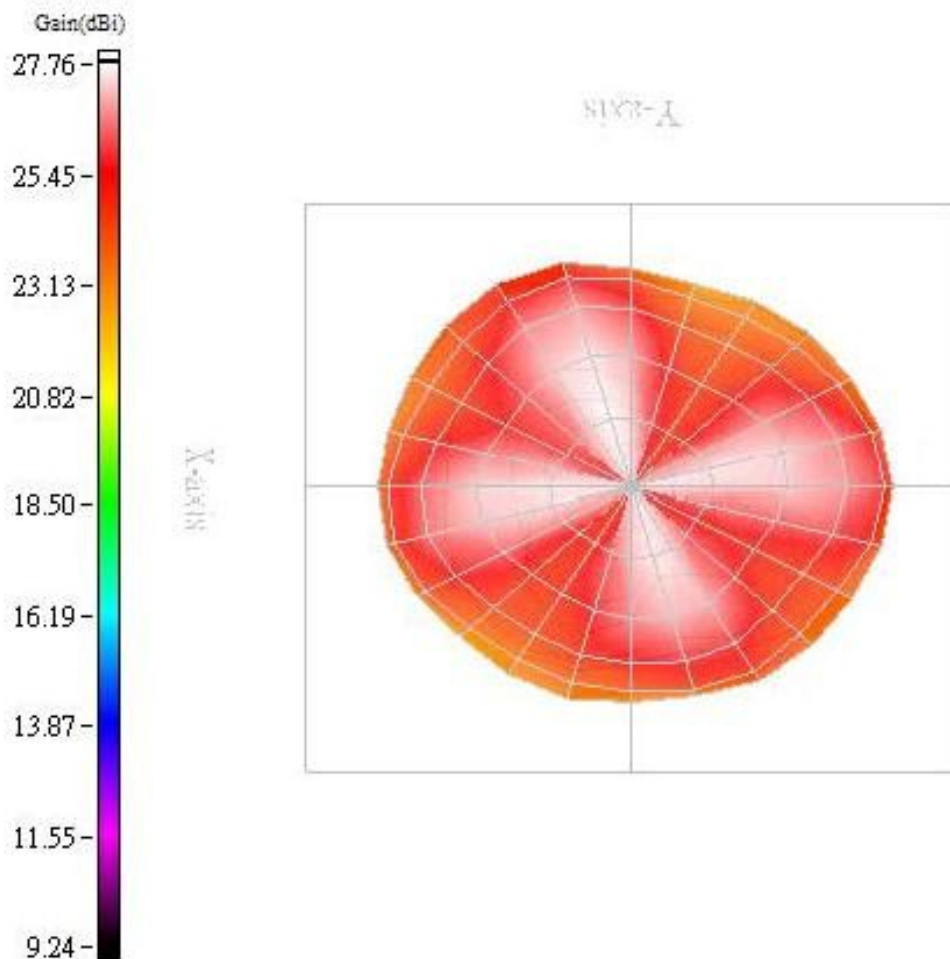

Max gain= 27.76dBi, at (0, 195)
Average Power= 19.78dBm
Directivity(dB)= 4.48
Efficiency= 19.28dB, 8462.62%

YZ

Model name

GPS ANTENNA

Test frequency / Polarization

1575.42 MHz / Vector YZ

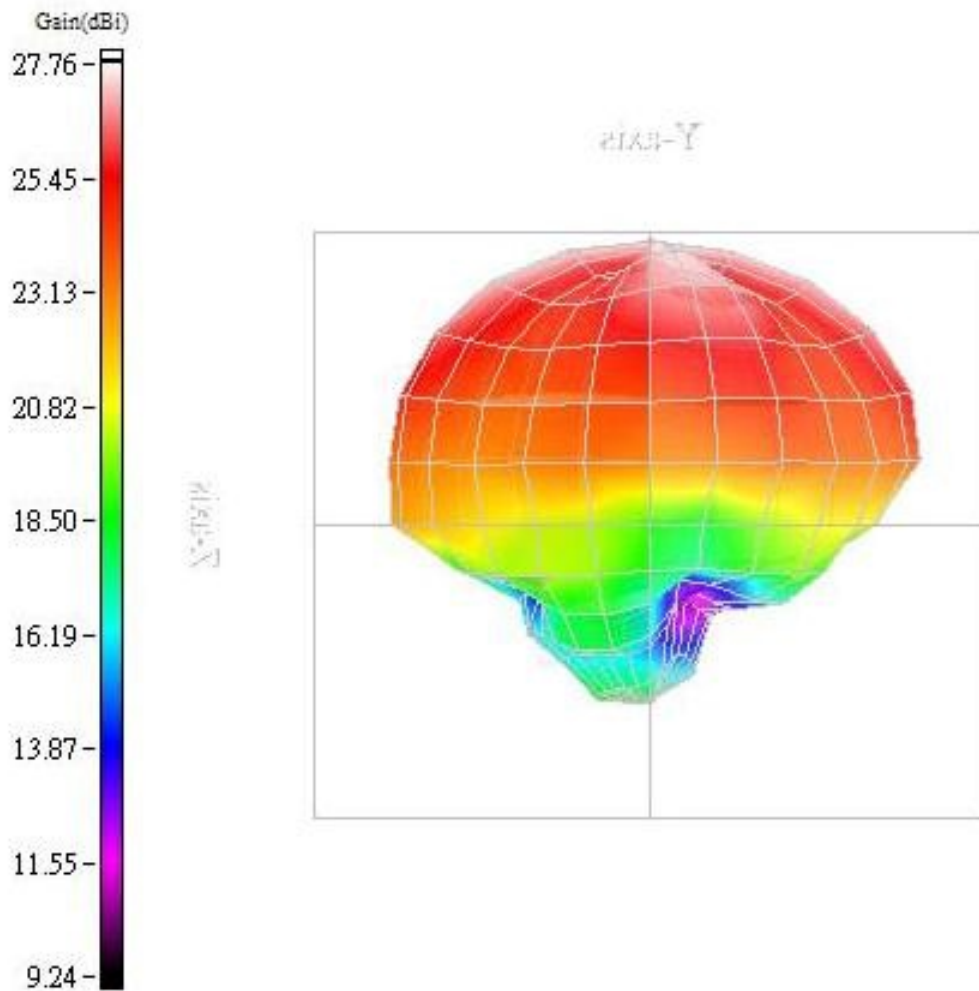

Max gain= 27.76dBi, at (0, 195)
Average Power= 19.78dBm
Directivity(dB)= 4.48
Efficiency= 19.28dB, 8462.62%

XZ

Model name

GPS ANTENNA

Test frequency / Polarization

1575.42 MHz / Vector XZ

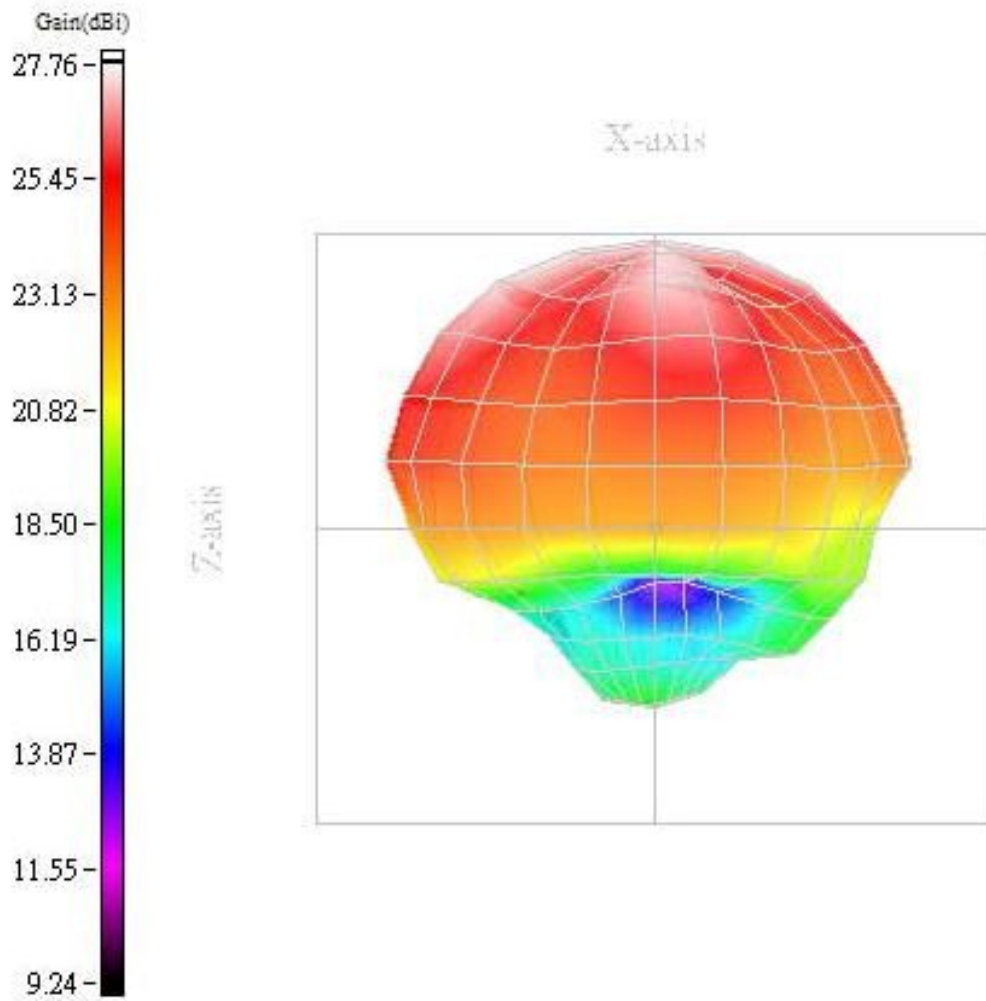

Max gain= 27.76dBi, at (0, 195)
Average Power= 19.78dBm
Directivity(dB)= 4.48
Efficiency= 19.28dB, 8462.62%

RF Solutions Ltd. Recycling Notice

Meets the following EC Directives:

DO NOT

Discard with normal waste, please recycle.

ROHS Directive 2011/65/EU and amendment 2015/863/EU

Specifies certain limits for hazardous substances.

WEEE Directive 2012/19/EU

Waste electrical & electronic equipment. This product must be disposed of through a licensed WEEE collection point. RF Solutions Ltd., fulfills its WEEE obligations by membership of an approved compliance scheme. Environment Agency producer registration number: **WEE/JB0104WV**.

Waste Batteries and Accumulators Directive 2006/66/EC

Where batteries are fitted, before recycling the product, the batteries must be removed and disposed of at a licensed collection point.

Disclaimer:

Whilst the information in this document is believed to be correct at the time of issue, RF Solutions Ltd does not accept any liability whatsoever for its accuracy, adequacy or completeness. No express or implied warranty or representation is given relating to the information contained in this document. RF Solutions Ltd reserves the right to make changes and improvements to the product(s) described herein without notice. Buyers and other users should determine for themselves the suitability of any such information or products for their own particular requirements or specification(s). RF Solutions Ltd shall not be liable for any loss or damage caused as a result of user's own determination of how to deploy or use R F Solutions Ltd's products. Use of RF Solutions Ltd products or components in life support and/or safety applications is not authorised except with express written approval. No licences are created, implicitly or otherwise, under any of RF Solutions Ltd's intellectual property rights. Liability for loss or damage resulting or caused by reliance on the information contained herein or from the use of the product (including liability resulting from negligence or where RF Solutions Ltd was aware of the possibility of such loss or damage arising) is excluded. This will not operate to limit or restrict RF Solutions Ltd's liability for death or personal injury resulting from its negligence.