

PART No.	CODE No.	NUMBER OF CONTACTS	A	B	C	D	E	F
DF9B- 9P-1V(32)	CL540-0134-7-32	9	10.1	8.3	6.6	3	4	8.4
DF9B-11P-1V(32)	CL540-0135-0-32	11	11.1	9.3	7.6	4	5	9.4
DF9B-13P-1V(32)	CL540-0136-2-32	13	12.1	10.3	8.6	5	6	10.4
DF9B-15P-1V(32)	CL540-0137-5-32	15	13.1	11.3	9.6	6	7	11.4
DF9B-17P-1V(32)	CL540-0138-8-32	17	14.1	12.3	10.6	7	8	12.4
DF9B-19P-1V(32)	CL540-0248-6-32	19	15.1	13.3	11.6	8	9	13.4
DF9B-21P-1V(32)	CL540-0140-0-32	21	16.1	14.3	12.6	9	10	14.4
DF9B-23P-1V(32)	CL540-0141-2-32	23	17.1	15.3	13.6	10	11	15.4
DF9B-25P-1V(32)	CL540-0142-5-32	25	18.1	16.3	14.6	11	12	16.4
DF9B-31P-1V(32)	CL540-0144-0-32	31	21.1	19.3	17.6	14	15	19.4
DF9B-41P-1V(32)	CL540-0221-0-32	41	26.1	24.3	22.6	19	20	24.4

NOTES 1 : LEAD CO-PLANARITY INCLUDE REINFORCED METAL FITTINGS SHALL BE 0.1mm MAX.
 ② CAV NO. IS INDICATED IN APPROX POSITION SHOWN.
 ③ 9 TO 25 CONTACT CONNECTORS HAVE ONE LOCK AT CENTER OF HOUSING.
 31 TO 41 CONTACT CONNECTORS HAVE TWO LOCKS AS PER DRAWING.

NO.	MATERIAL	FINISH . REMARKS	NO.	MATERIAL	FINISH . REMARKS
3	BRASS	SURFACE:TIN PLATED(REFLOW FINISH)1μm min UNDER PLATING:COPPER 0.3μm min	8	PS	CLEAR(REINFORCEMENT COLLAR)
2	PHOSPHOR BRONZE	TIN PLATED(HOT DIP) 1μm min	7	PS	BLACK(PLASTIC REEL)
1	POLYAMIDE	BEIGE, UL94V-0	6	POLYIMIDE	BROWN(HEAT-RESISTANCE TAPE)
			5	POLYESTER	CLEAR(COVER TAPE)
			4	PS	CLEAR(EMBOSSED CARRIER TAPE)

UNITS	SCALE	COUNT	DESCRIPTION OF REVISIONS	DESIGNED	CHECKED	DATE
mm	5 : 1	2	DIS-H-008010	YN. SAKAMOTO	YH. MICHIDA	13.07.05

APPROVED : KH. IKEDA	12.02.27	DRAWING NO.	EDC3-341299-02
CHECKED : AR. TAKAHASHI	12.02.24	PART NO.	DF9B-*P-1V(32)
DESIGNED : SH. HOSODA	12.02.24	CODE NO.	CL540-
DRAWN : KR. AJITO	12.02.24		

Apr.1.2017 Copyright 2017 HIROSE ELECTRIC CO., LTD. All Rights Reserved.

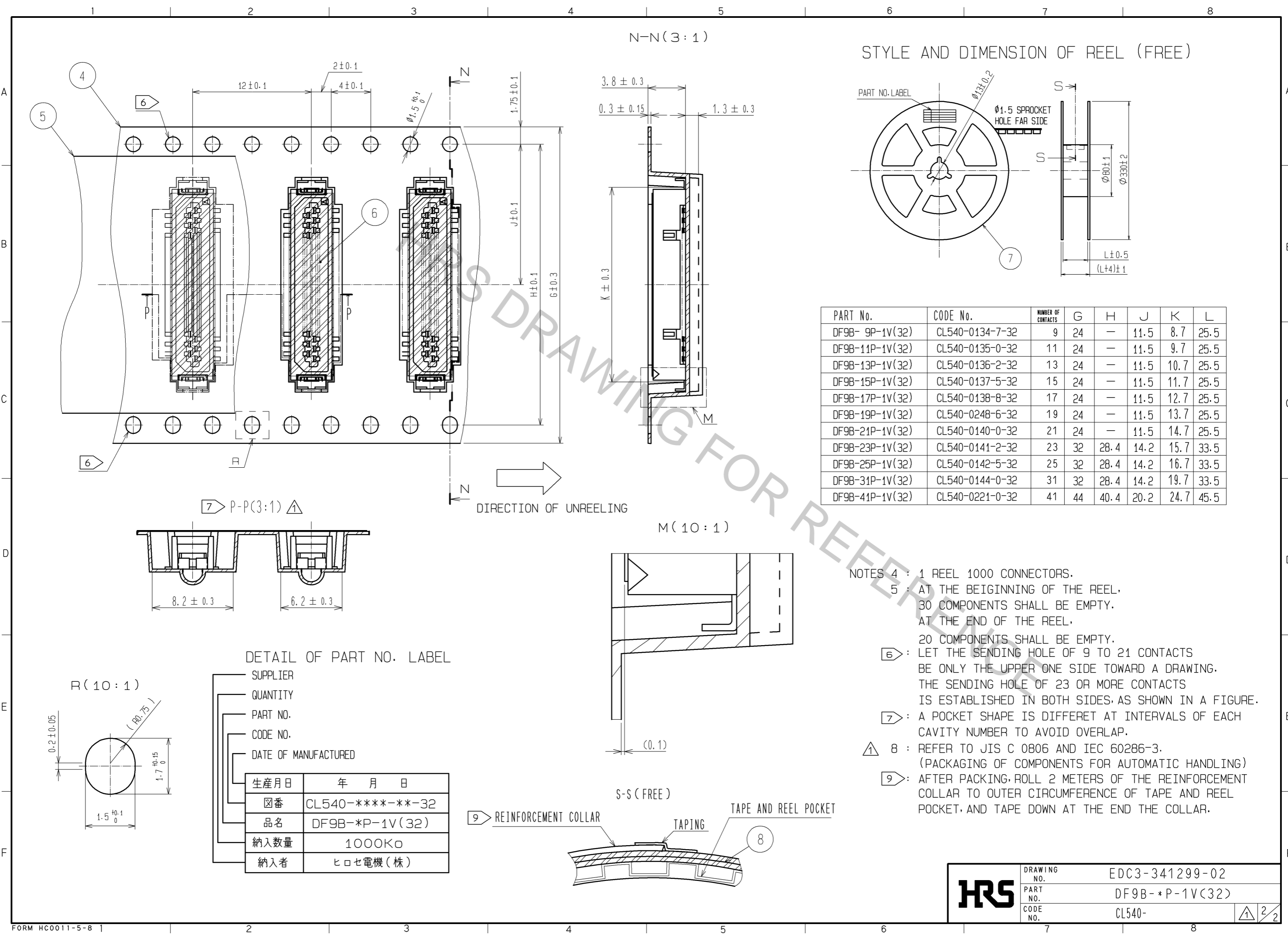

STYLE AND DIMENSION OF REEL (FREE)

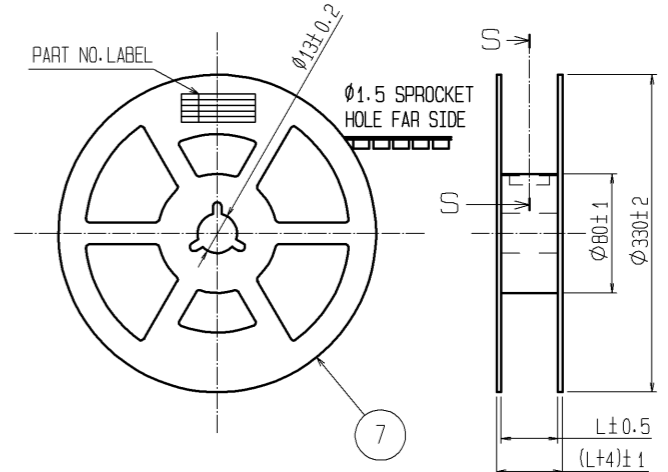

PART No.	CODE No.	NUMBER OF CONTACTS	G	H	J	K	L
DF9B-9P-1V(32)	CL540-0134-7-32	9	24	—	11.5	8.7	25.5
DF9B-11P-1V(32)	CL540-0135-0-32	11	24	—	11.5	9.7	25.5
DF9B-13P-1V(32)	CL540-0136-2-32	13	24	—	11.5	10.7	25.5
DF9B-15P-1V(32)	CL540-0137-5-32	15	24	—	11.5	11.7	25.5
DF9B-17P-1V(32)	CL540-0138-8-32	17	24	—	11.5	12.7	25.5
DF9B-19P-1V(32)	CL540-0248-6-32	19	24	—	11.5	13.7	25.5
DF9B-21P-1V(32)	CL540-0140-0-32	21	24	—	11.5	14.7	25.5
DF9B-23P-1V(32)	CL540-0141-2-32	23	32	28.4	14.2	15.7	33.5
DF9B-25P-1V(32)	CL540-0142-5-32	25	32	28.4	14.2	16.7	33.5
DF9B-31P-1V(32)	CL540-0144-0-32	31	32	28.4	14.2	19.7	33.5
DF9B-41P-1V(32)	CL540-0221-0-32	41	44	40.4	20.2	24.7	45.5

- NOTES
- 4 : 1 REEL 1000 CONNECTORS.
 - 5 : AT THE BEGINNING OF THE REEL, 30 COMPONENTS SHALL BE EMPTY. AT THE END OF THE REEL, 20 COMPONENTS SHALL BE EMPTY.
 - 6 : LET THE SENDING HOLE OF 9 TO 21 CONTACTS BE ONLY THE UPPER ONE SIDE TOWARD A DRAWING. THE SENDING HOLE OF 23 OR MORE CONTACTS IS ESTABLISHED IN BOTH SIDES, AS SHOWN IN A FIGURE.
 - 7 : A POCKET SHAPE IS DIFFERET AT INTERVALS OF EACH CAVITY NUMBER TO AVOID OVERLAP.
 - 8 : REFER TO JIS C 0806 AND IEC 60286-3. (PACKAGING OF COMPONENTS FOR AUTOMATIC HANDLING)
 - 9 : AFTER PACKING, ROLL 2 METERS OF THE REINFORCEMENT COLLAR TO OUTER CIRCUMFERENCE OF TAPE AND REEL POCKET, AND TAPE DOWN AT THE END THE COLLAR.

DETAIL OF PART NO. LABEL

SUPPLIER

QUANTITY

PART NO.

CODE NO.

DATE OF MANUFACTURED

生産月日	年 月 日
図番	CL540-****-**-32
品名	DF9B-*P-1V(32)
納入数量	1000K口
納入者	ヒロセ電機(株)

