

# Snipe Nose Side Cutting Pliers

Stork Beak Pliers

DIN ISO 5745 IEC 60900 DIN EN 60900

26

- > distortion-tolerant, flexible precision tips
- > half-round, long, pointed jaws
- > hardened cutting edges (approx. 61 HRC) for soft, medium hard and hard wire
- > vanadium steel; forged, multi-stage oil-hardened

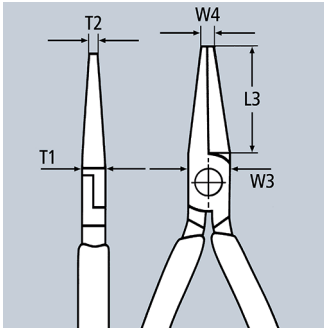

26 18 200 US

⚡ 1000V ASTM



26 28 200 SBA

∠40° ⚡ 1000V ASTM

Product Number	Packaging	↔ Inch mm	⚡ 1000V ASTM	Pliers	Head	Handles	Cutting capacities		Dimensions						⚖ lbs
							⊙ Ø Inch Ø mm	⊙ Ø Inch Ø mm	L3 Inch mm	T1 Inch mm	W3 Inch mm	W4 Inch mm	T2 Inch mm		
26 18 200 US	X	8 200	⚡ 1000V ASTM	black atramentized	polished	insulated, multi-component handles, ASTM-tested	1/8 3.2	3/32 2.2	2 7/8 73.0	3/8 9.5	45/64 18.0	1/8 3.0	3/32 2.5	0.45	
26 28 200 SBA	X	8 200	∠40° ⚡ 1000V ASTM	black atramentized	polished	insulated, multi-component handles, ASTM-tested	1/8 3.2	3/32 2.2	2 7/8 73.0	3/8 9.5	45/64 18.0	1/8 3.0	3/32 2.5	0.46	

