

DESCRIPTION: M5 FEMALE - RIGHT ANGLE - 4 POSITION

NOTE:

MATERIAL

HOUSING: PBT UL94V-0, BLACK
 CONTACT: BRASS
 NUT: BRASS
 O-RING: NBR, BLACK
 BACK HOUSING: PBT UL94V-0, BLACK
 DOWN HOUSING: PBT UL94V-0, BLACK

FINISH

CONTACT: GOLD PLATED
 UNDER PLATE: NICKEL
 NUT: STAIN NICKEL

ELECTRICAL:

RATED CURRENT: 1A
 RATED VOLTAGE: 60V
 INSULATION RESISTANCE: 100 MOhms MIN.
 CONTACT RESISTANCE: 10 mOhms MAX.
 WATER PROOF: IP67

ENVIRONMENT:

OPERATION TEMPERATURE: -40°C TO +85°C
 MAX ASSEMBLY TORQUE: 1.5 in lbs

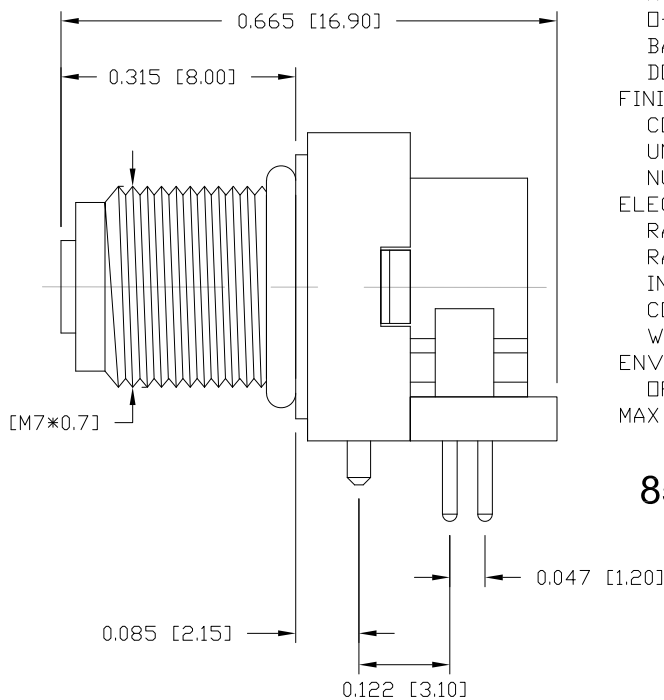
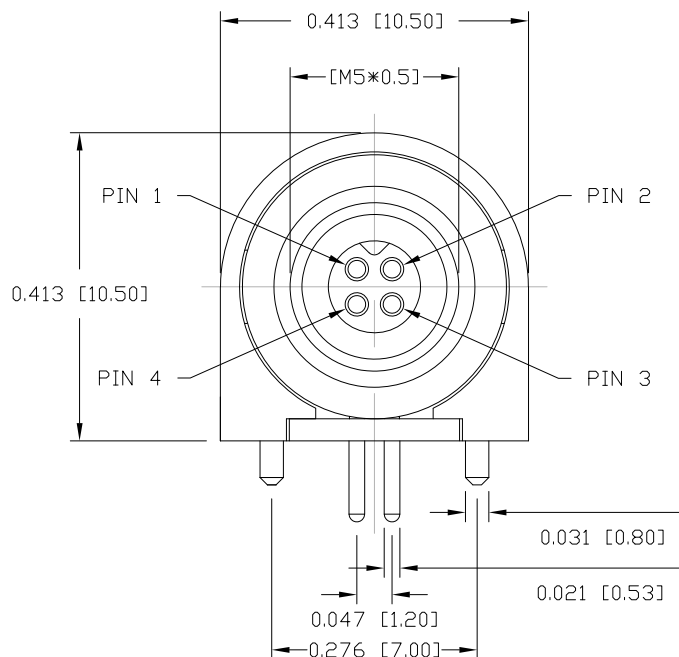

853-004-213R00Y

1 = GOLD FLASH
 4 = 10u" GOLD

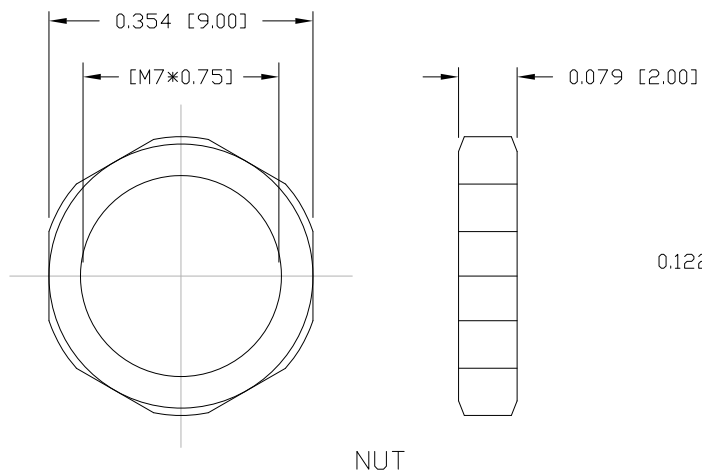

NUT

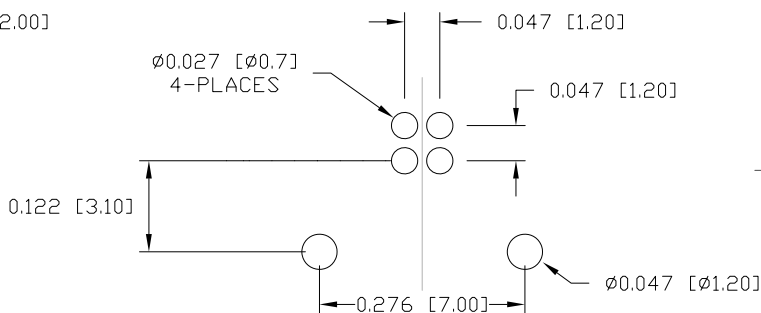

P.C.B LAYOUT

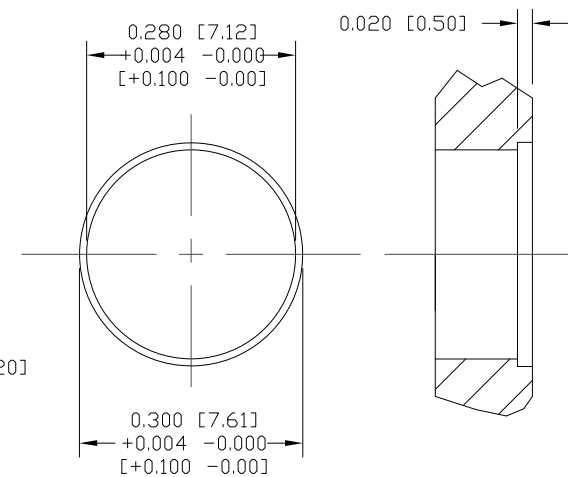

PANEL CUT-OUT

MAX. PANEL THICKNESS: 0.125 [3.17]

TOLERANCE:

.X ±0.008 [±0.2]
 .XX ±0.004 [±0.1]
 .XXX ±0.002 [±0.05]

RoHS COMPLIANT

DO NOT SCALE FROM DRAWING



THESE DRAWINGS AND SPECIFICATIONS ARE THE PROPERTY OF NorComp AND SHALL NOT BE REPRODUCED, COPIED OR USED AS THE BASIS FOR THE MANUFACTURE OR SALE OF APPARATUS WITHOUT WRITTEN PERMISSION.

DRAWN:

M. SIGMON

DATE:

03-04-16

NorComp

SCALE: NTS

SHEET 1 OF 1

REV 6

DWG NO.

853-004-213R00Y