

**STRAIGHT BULKHEAD PLUG CRIMP TYPE
CABLE 2.6/50 S - PACK. 100**

R128.083.827
SERIES BMA COM

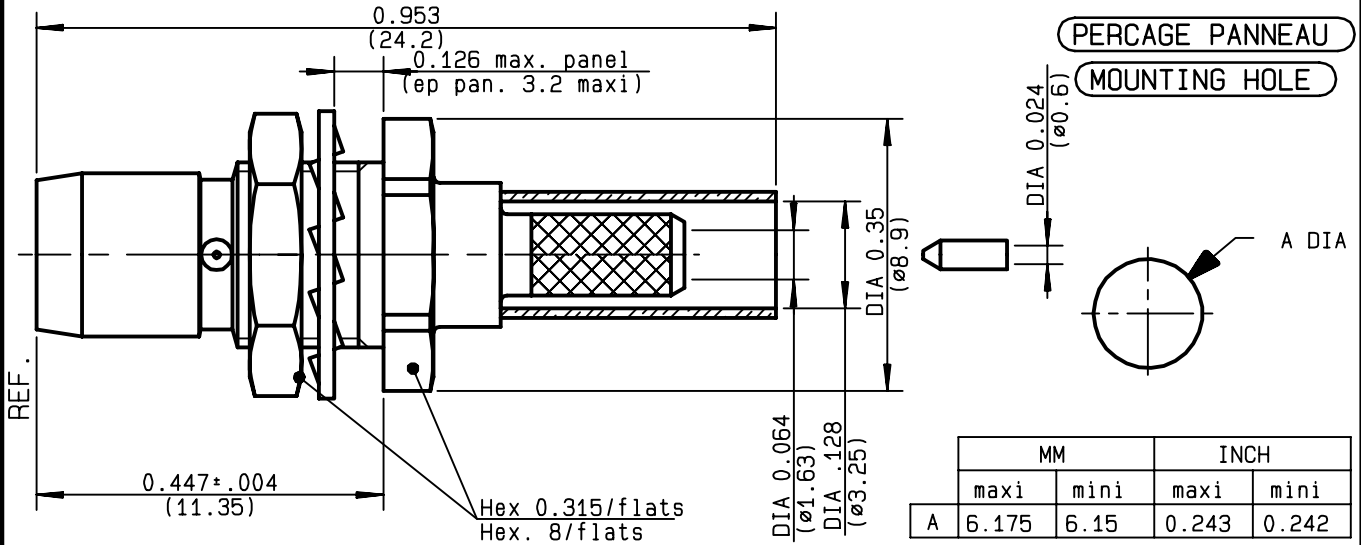

NOMINAL IMPEDANCE	50 Ω
FREQUENCY RANGE	0-12.4 GHz
TEMPERATURE RATING	-65/+125 °C
V.S.W.R	1.15 + .02 x F(GHz)Maxi
RF INSERTION LOSS	0.03 √F(GHz) dB Maxi
VOLTAGE RATING	350 Veff Maxi
DIELECTRIC WITHSTANDING VOLTAGE	1000 Veff Mini
INSULATION RESISTANCE	5000 MΩMini
HERMETIC SEAL	NA Atm.cm ³ /s
LEAKAGE (pressurized only)	NA
MECHANICAL DURABILITY	500 Cycles
WEIGHT	3.09 gr
SPECIFICATION	

CABLES : **KX 22A**
RG 188
RG 316

OTHERS CHARACTERISTICS

CABLE RETENTION	110	N Mini
CENTER CONTACT RETENTION		
Axial force - mating end	18	N Mini
Axial force - opposite end	18	N Mini
Torque	NA	cm.N Mini
RECOMMENDED TORQUES		
Mating	NA	cm.N
Panel nut	150	cm.N
Clamp nut	NA	cm.N

CONNECTOR PARTS	MATERIALS	FINISH	(all values are given in micrometers)
BODY	BRASS	BBR 2	
OUTER CONTACT			
CENTER CONTACT	BRONZE	GOLD 1.3 OVER COPPER 2	
INSULATOR	PTFE	-	
GASKET		-	
OTHERS PIECES	BRASS	BBR 2	

ISSUE 9926A01	CREATION DATE 01/10/1996	FILE PART-NUMBER EPC96-06
-------------------------	------------------------------------	-------------------------------------



BAFFERT

The information given here is subject to change without notice.
Design changes may be in order to improve the product .

Connect to the future



R128.083.827

ISSUE 9926A01 SERIES BMA COM

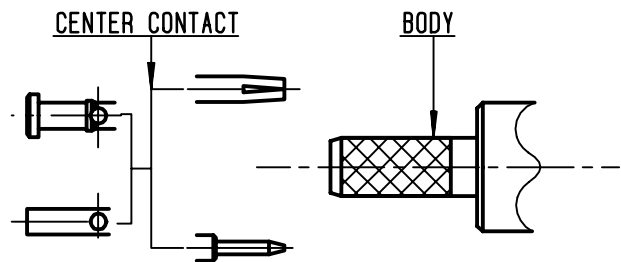
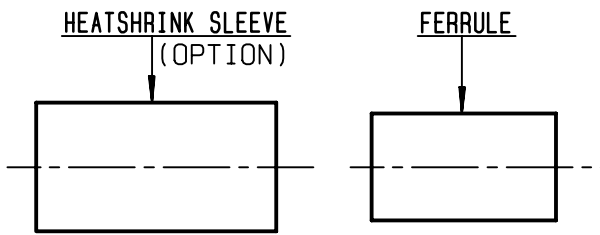

①

Slide ferrule and heatshrink sleeve onto cable .
(R280.637.020 - Option)
Strip the cable
-

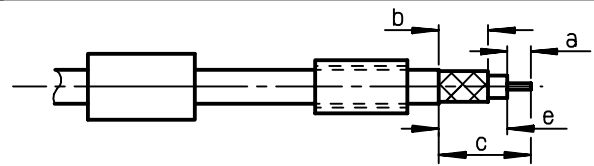

Stripping	a	b	c	d	e
inch	0.059	0.256	0.421	0	0.362
mm	1.5	6.5	10.7		9.2

②

Slide center contact on until it bottoms against cable dielectric .
Solder center contact .
Clean soldered area .
-
-

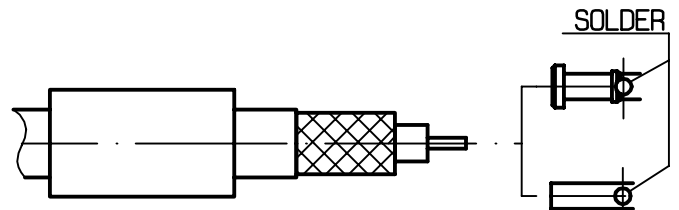

③

Fan the braid .
Slide cable into body until it bottoms against insulator .
Slide ferrule over the braid .
(In direction F)

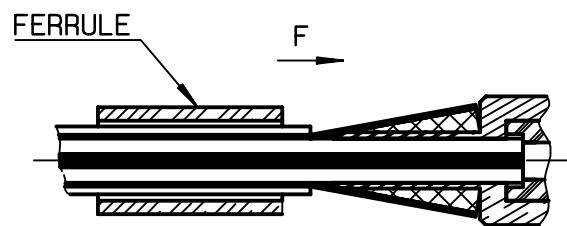

④

Crimp the ferrule with crimping tool R 282 211 000 (Hex. : 3.25mm) or crimping tool R 282 293 000 (M22520/5-01) + dies R 282 235 003 (M22520/5-03)
Cut the excess of braid if necessary
Slide sleeve over ferrule and heatshrink in place (Option).
-
-

Shrink the heatshrink sleeve

